

9-Watt LED Luminaires

Product Data Sheet

Engineered Products Company's (EPCO) 9-Watt LED Keyless and Pull Chain Luminaires' low profile illumination is ideal for small area lighting applications. Offering optimum lighting performance and energy efficiency, the annual operating cost is \$5.52, an 85% savings vs. an incandescent lamp, a 31% saving vs. a compact fluorescent lamp. Just another innovation from EPCO designed to save you energy and money!

- Available Keyless or with Pull Chain.
- Includes 9-Watt Bi-Pin LED Lamp and Polycarbonate Lamp Diffuser.
- Can be used with standard wall switch.
- Impact resistant construction.
- 7" wire conductors.
- Medium Base fits 3.25" or 4.0" Outlet Box.



Keyless
(P/N: 16531)



Pull Chain
(P/N: 16536)



Bi-Pin LED Lamp
(P/N: 15676)



9-Watt LED Luminaire Specifications

	P/N: 16531	P/N: 16536
Lumen Output	800 Lumens	800 Lumens
Color Temperature	2700K	2700K
Voltage	120-Volts	120-Volts
Wattage	9-Watts	9-Watts
Efficacy	88 lm/W	88 lm/W
Applications	Dry Environments Only	Dry Environments Only
Operating Temperature	32°F (0°C) to 104°F (40°C)	32°F (0°C) to 104°F (40°C)
Diffuser	Snap-On, Frosted Acrylic	Snap-On, Frosted Acrylic
Switch	Standard Wall Switch (Keyless)	Standard Wall Switch (Pull Chain)
Certifications	<ul style="list-style-type: none"> ■ UL Listed ■ Meets the requirements of the 2023 National Electrical Code: Articles 410.16(A)(B)(1)(3), (D)(1)(3), 410.52, and 410.80(A)(B). 	

TYPICAL APPLICATIONS:

- Closets
- Garages
- Attics
- Utility Rooms
- Basements
- Storage Buildings
- Commercial, Industrial, and Residential Lighting
- And more...

DIMENSIONAL REFERENCES:

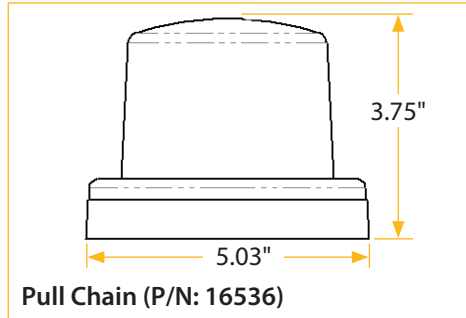
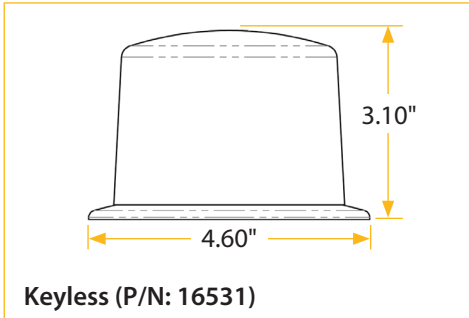

PART NUMBERS:

Catalog Number	UPC Number	Description	Order Unit	Unit Qty	Unit Pkg	Units/Case	TL Case Qty	Min Order Qty	MM Req	Ship Wt (Lbs)
16531	16531	Keyless	EA	1	BX	24	24	24	Yes	11
16536	16536	Pull Chain	EA	1	BX	24	24	24	Yes	11
15676	15676	Bi-Pin LED Lamp	EA	1	BX	25	25	25	Yes	8

UNITS OF MEASURE KEY

Order Unit: The Unit to be ordered; **Order Qty:** Number of pieces in each Unit; **Unit Pkg:** Packaging types - BG (Bag), BX (Box), BRL (Barrel); **Units/Case:** Unit packages contained in the Case; **TL Case Qty:** The total number of items in each Master Case; **Min Order Qty:** The smallest Unit that can be ordered; **MM Req:** Must order multiples of the Unit in the stated quantities; **Ship Wt (Lbs):** Total weight of the units per Carton

E02-150-011 E1 (07/24 AK)
©2024 Engineered Products Company. All Rights Reserved.

