



ENGINEERED PRODUCTS CO.

5401 Smetana Drive • Minnetonka, MN 55343
Phone: 952.767.8780 / 800.336.1976 • Fax: 952.767.8786 / 800.336.2801
Web Site: engproducts.com

LIGHTING
PRODUCTS

P
r
o
d
u
c
t
•
D
a
t
a
•
S
h
e
e
t

LANDSCAPE LIGHTING

Landscape SplicePost™ and LightPosts™

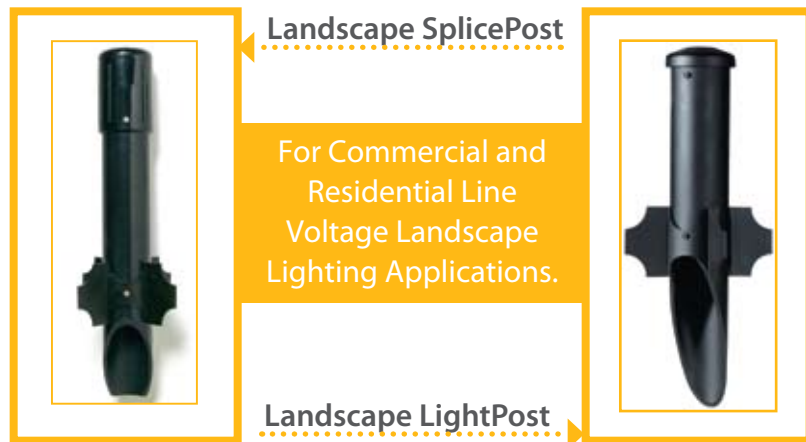

- Suitable for use in wet locations. • Ready to install. No assembly required.
- 3" Outside diameter PVC LightPost Fixture Fitting.
- Replaces EMT, conduit connectors and weatherproof boxes.
- 100% UV, corrosion and shatter-resistant.
- Accommodates a 1/2" trade size conduit nipple to mount a variety of lighting fixtures.
- The Uni-Stabilizer™ is made of durable polycarbonate material featuring four uniquely shaped concaved stabilizing blades. This design enables ground material to be easily packed around the Landscape LightPost or SplicePost as well as provide solid in-ground support. The uni-stabilizer also helps resist against ground movement typically caused by ground freezing and thawing.
- The 20 degree slanted top virtually eliminates water pooling or leakage into the interior of the Landscape LightPost and SplicePost.
- 65 Degree angled to bottom enables easy entry of cable or conduit.
- Compact and attractive regardless of final height placement.

Compared to other designs, these landscape lighting fixture fittings are a cost-effective and simple solution for permanent landscape, accent lighting or sign facade.

Landscape SplicePost

SpliceCap™ accommodates a 1/2" trade size conduit nipple.

NEC Article 314.15 ... boxes, conduit bodies, and fittings installed in wet locations shall be listed for use in wet locations.

NEC Article 314.16 (A) ... boxes 1650 cm (100 in.) or less, other than those described in Table 314.16 (A), and nonmetallic boxes shall be durably and legibly marked by the manufacturer with their volume.

NEC Article 314.17 - Conductors entering boxes, conduit bodies, or fittings shall be protected from abrasion and shall comply with 314.17 (A) through (D).

Where raceway or cable is installed with metal boxes or conduit bodies, the raceway or cable shall be secured to such boxes and conduit bodies.

Replaces EMT, conduit connectors and weatherproof boxes.

Uni-Stablizer features unique concave stabilizing blades that allows ground material to be easily packed around the Landscape SplicePost for fast, easy, and secure installation.

The Uni-Stablizer helps minimize the Landscape SplicePost's movement typically caused by ground freezing and thawing.

The Landscape SplicePost is shatter resistant to denting or cracking typically caused by landscape maintenance equipment. It is also corrosion and UV resistant and impervious to changing environmental conditions.

When wiring multiple lighting fixtures in series, the Landscape SplicePost's angled bottom allows UF Cable or Conduit to easily enter at different depths to eliminate cable congestion.

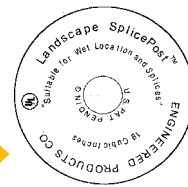

Engineered Products Company's Landscape SplicePost for outdoor lighting fixtures is different from any other "hollow pipe" style landscape lightpost on the market. It features a splice compartment within the SpliceCap that is UL Listed for splicing line voltage conductors to the fixture.



The PVC SpliceCap is non-metallic and suitable for the majority of outdoor lighting fixtures on the market.

Landscape SplicePost... (CONTINUED)

The SpliceCap's 19 cubic inch box volume can house two 20 AMP circuit conductors.

Eight internal "Stops" seat and firmly hold the Separator Disk™ in place when the SpliceCap is positioned on the PVC Pipe.

SpliceCap compartment fully encloses and protects the circuit conductor(s) from moisture, dirt and abrasion.

Raised "Grips" simplify installation and removal of the SpliceCap.

A Connector(s) secures the incoming supply line cable to the Separator Disk.

Incoming supply line cable.

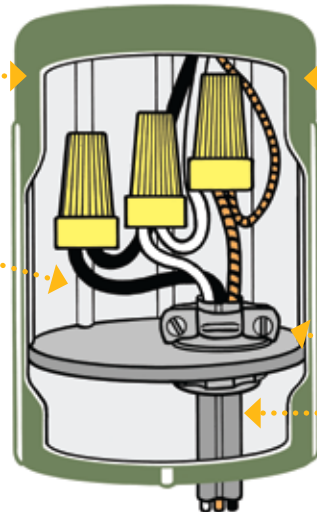

Landscape SplicePost - SpliceCap cut-away

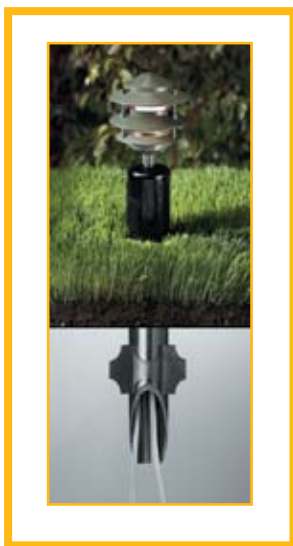

Landscape SplicePost - PVC

- The Landscape SplicePost is UL Listed as a "Luminaire Fitting," suitable for use in wet locations.
- The Landscape SplicePost features a Separator Disk and SpliceCap that creates an integral "junction box" that is UL Listed and suitable for splicing.
- U.S. Patent Number: 6,877,886.

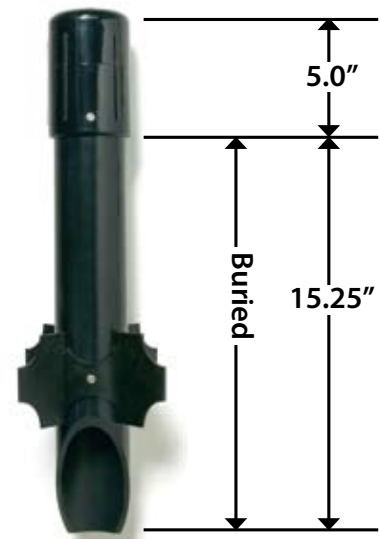

Catalog Number	UPC Number	Description	Standard Package	Standard Package Ship Wt. (lbs.)
LSPB	17200	Landscape SplicePost, PVC - Black	9/Carton	21
LSPBZ	17205	Landscape SplicePost, PVC - Bronze	9/Carton	21
LSPG	17210	Landscape SplicePost, PVC - Green	9/Carton	21
17230	17230	SplicePost Cap, PVC - Black, with Separator Disk	1/Pkg.	1
17232	17232	SplicePost Cap, PVC - Bronze, with Separator Disk	1/Pkg.	1
17234	17234	SplicePost Cap, PVC - Green, with Separator Disk	1/Pkg.	1

Note: Landscape SplicePosts are ONLY sold in case quantities of 9 per carton.

Landscape LightPost

Catalog Number	UPC Number	Description	Standard Package	Standard Package Ship Wt. (lbs.)
LLPN25	12700	Landscape LightPost, 17.5" - White	9/Carton	21
LLPN25B	12701	Landscape LightPost, 17.5" - Black	9/Carton	21
LLPN25VG	12702	Landscape LightPost, 17.5" - Verde Green	9/Carton	21
LLPN25BL	12704	Landscape LightPost, 23.5" - Black	9/Carton	25
E04-002-004	14025	Landscape LightPost Replacement Cap - Black	1/Pkg.	1
E04-002-004VG	14026	Landscape LightPost Replacement Cap - Verde Green	1/Pkg.	1

Note: The Landscape LightPost should be used with a UL Listed Fixture and a grounding means (i.e., ground bonded third wire) suitable for use in wet locations. Landscape LightPosts are sold ONLY in case quantities of nine per Carton.

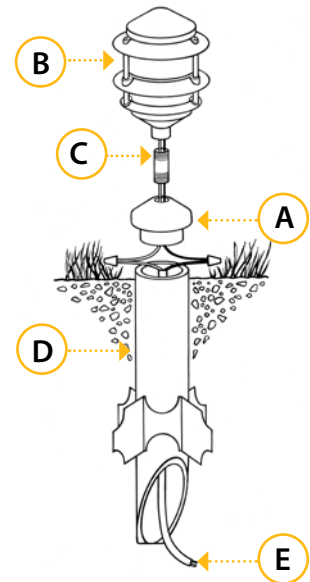
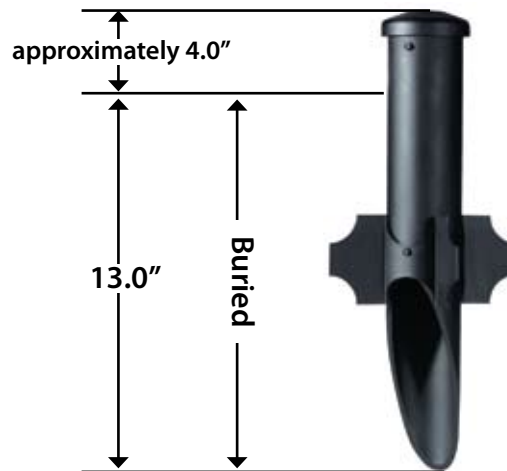
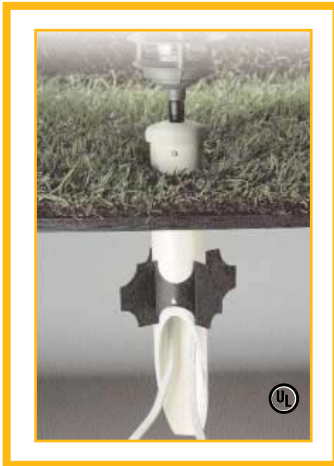

- A** The Nesting Cap fits securely into the Landscape LightPost and can easily be removed to facilitate maintenance or removal of the light fixture.
- B** Light Fixture **C** 1/2" Nipple (not supplied) **D** Landscape PowerPost
- E** Incoming UF supply line or conduit.

Distributed By:

Engineered Products Company • 5401 Smetana Drive • Minnetonka, MN 55343
Phone: 952.767.8780 / 800.336.1976 • Fax: 952.767.8786 / 800.336.2801 • engproducts.com